



Losberger SAS

58A rue du Dessous des Berges
75013 Paris - France

Tel. +33 (0)1 46 72 42 69
Fax. +33 (0)1 45 85 48 46

Email: contact@losbergerdeboer.com
Internet: www.losberger-rds.com

Presentation of Airshelter range

Airshelter tents by Losberger SAS are reliable tents made of an inflatable rubber structure and a stitched textile cover. They are very flexible and can be equipped with features such as waterbelts, translucent roof, integrated shower system among others.

Our inflatable tents are rigorously tested and used as field hospitals, command posts or NBC colpro stations by a considerable number of fire fighting, rescue-, Nato-Forces and Non Governmental Organisations.

Airshelter are very user-friendly and can be deployed quickly using a minimum of human effort.



Features

- Airshelters are inflated in less than 3 minutes.
- Airframes allow automatic deployment.
- Airshelters are equipped with built-in safety valves.
- Airshelters stay up for several days without reinflating.
- Airshelters are available in different colors.
- Airshelters can be connected to all models.



Fields of use

- Fire Fighting
- Field Hospitals
- Military operations
- Rescue purposes

with polygonal structure

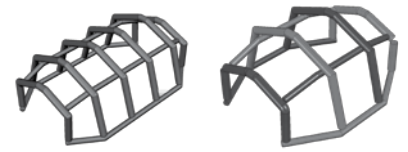

Airshelter IV

Inflatable rescue shelter, Assembled and taken down in 3 min. by 2 persons. Ample headroom on floor area. In- deflated with Blower K or BA cylinder. Separate pressure chambers with overpressure valves. Incl. 2 doors zippers, connectable fixtures on inside to suspend accessories, fixed groundsheet, repairset, handpump, gey ropes, pegs, hammer and carrying bag.

Material:

Fabric: Standard Airtex165 colour red, Frame: Airtex200

Groundfloor: Airtex320

Length: 820cm, Width: 540cm, Height: 300cm, Weight: 100kg
part no.: AIR200-4



Airshelter VIII

Inflatable rescue shelter, Assembled and taken down in 4 min. by 2 persons. Ample headroom on floor area. In- deflated with Blower K or BA cylinder. Separate pressure chambers with overpressure valves . Incl.2 doors zippers, connectable fixtures on inside to suspend accessories, fixed groundsheet, repairset, handpump,guy ropes, pegs, hammer and carrying bag.

Material:

Fabric: Standard Airtex165 colour red, Frame: Airtex200

Groundfloor: Airtex320

Length: 1 000cm, Width: 650cm, Height: 315cm, Weight: 115kg
part no.: AIR200-8



Airshelter XI

Inflatable rescue shelter, Assembled and taken down in 3 min. by 2 persons. Ample headroom on floor area. In- deflated with Blower K or BA cylinder. Separate pressure chambers with overpressure valves . Incl.2 doors zippers, connectable fixtures on inside to suspend accessories, fixed groundsheet, repairset, handpump,guy ropes, pegs, hammer and carrying bag.

Material:

Fabric: Standard Airtex165 colour red, Frame: Airtex200

Groundfloor: Airtex320

NSN: 8340-17-115-5828

Length: 640cm, Width: 540cm, Height: 300cm, Weight: 85kg
part no.: AIR200-11



with two-slope roof



Airshelter III

Inflatable rescue shelter, Assembled and taken down in 2 min. by 2 persons. Ample headroom on floor area. In- deflated with Blower K or BA cylinder. Separate pressure chambers with overpressure valves . Incl.2 doors zippers, connectable fixtures on inside to suspend accessories, fixed groundsheet, repairset, handpump,guy ropes, pegs, hammer and carrying bag.

Material:

Fabric: Standard Airtex165 colour red, Frame: Airtex200

Groundfloor: Airtex320

Length: 600cm, Width: 450cm, Height: 280cm, Weight: 75kg
part no.: AIR200-3



Airshelter III-L

Inflatable rescue shelter, Assembled and taken down in 2 min. by 2 persons. Ample headroom on floor area. In- deflated with Blower K or BA cylinder. Separate pressure chambers with overpressure valves. Extra strong frame for increased snowload.. Incl. 2 doors zippers, connectable fixtures on inside to suspend accessories, fixed groundsheet, repairset, handpump,guy ropes, pegs, hammer and carrying bag.

Material:

Fabric: Standard Airtex165 colour red, Frame: Airtex200

Groundfloor: Airtex320

Length: 700cm, Width: 500cm, Height: 295cm, Weight: 130kg
part no.: AIR200-3L



Airshelter V

Inflatable rescue shelter, Assembled and taken down in 2 min. by 2 persons. Ample headroom on floor area. In- deflated with Blower K or BA cylinder. Separate pressure chambers with overpressure valves . Incl.2 doors zippers, connectable fixtures on inside to suspend accessories, fixed groundsheet, repairset, handpump,guy ropes, pegs, hammer and carrying bag.

Material:

Fabric: Standard Airtex165 colour red, Frame: Airtex200

Groundfloor: Airtex320

Length: 370cm, Width: 300cm, Height: 240cm, Weight: 55kg
part no.: AIR200-5



with two-slope roof



Airshelter VII

Inflatable rescue shelter, assembled and taken down in 3 min. by 2 persons. Ample headroom on floor area. In- deflated with Blower K or BA cylinder. Separate pressure chambers with overpressure valves . Incl.2 doors zippers, connectable fixtures on inside to suspend accessories, fixed groundsheet, repairset, handpump,guy ropes, pegs, hammer and carrying bag.

Material:

Fabric: Standard Airtex165 colour red, Frame: Airtex200

Groundfloor: Airtex320

Length: 600cm, Width: 570cm, Height: 300cm, Weight: 88kg
part no.: AIR200-7



Airshelter IX

Inflatable rescue shelter, assembled and taken down in 2 min. by 2 persons. Ample headroom on floor area. In- deflated with Blower K or BA cylinder. Separate pressure chambers with overpressure valves . Incl.2 doors zippers, connectable fixtures on inside to suspend accessories, fixed groundsheet, repairset, handpump,guy ropes, pegs, hammer and carrying bag.

Material:

Fabric: Standard Airtex165 colour red, Frame: Airtex200

Groundfloor: Airtex330

Length: 500cm, Width: 400cm, Height: 240cm, Weight: 60kg
part no.: AIR200-9



Airshelter XIII

Inflatable rescue shelter, assembled and taken down in 2 min. by 2 persons. Ample headroom on floor area. In- deflated with Blower K or BA cylinder. Separate pressure chambers with overpressure valves . Incl.2 doors zippers, connectable fixtures on inside to suspend accessories, fixed groundsheet, repairset, handpump,guy ropes, pegs, hammer and carrying bag.

Material:

Fabric: Standard Airtex165 colour red, Frame: Airtex200

Groundfloor: Airtex320

Length: 500cm, Width: 500cm, Height: 285cm, Weight: 65kg
part no.: AIR201-3



The Airshelter Trendline Shelters are user friendly, no special knowledge or skill is required. All Trendline Shelter sizes are standardized to make all shelters fit easily together.

Features

- TrendLine shelters are inflated in less than 3 minutes.
- TrendLine shelters allow automatic deployment.
- TrendLine shelters are equipped with built-in safety valves.
- TrendLine shelters stay up for several days without reinflating.
- TrendLine shelters are available in different colors.
- TrendLine shelters can be connected to all other Airshelter and ResQshelter models.



Fields of use

- Field hospital
- Command post
- Shelter
- Mass decontamination
- Base camp
- Compound

The Trendline tents are inflatable rescue shelters which can be assembled and taken down in less than 5 minutes by 2 persons; apart from the frame tubes, the floor surface is completely free. The frame is equipped with 2 overpressure valves.

Trendline tents are equipped with 2 zipped doors, a fixed groundsheet, repair kit, handpump, guy ropes, pegs, hammer and carrying bag.

Materials :

Cover : Standard Airtex 165 colour white-grey

Floor : Airtex 320

Frame : Airtex 200

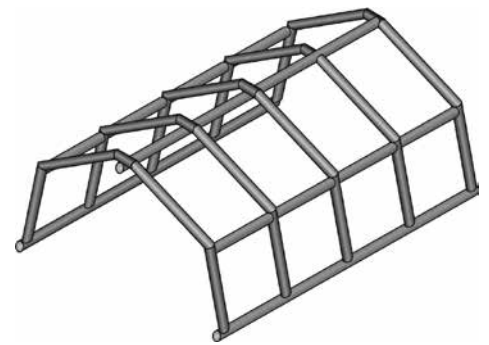

	TL20	TL30	TL40	TL50	TL60
Article code	AIR200-20	AIR200-30	AIR200-40	AIR200-50	AIR200-60
Arches	3	4	5	6	7
Length (cm)	370	550	730	910	1100
Width (cm)	605	605	605	605	605
Height (cm)	325	325	325	325	325
Weight (kg)	54	80	106	132	154
Packed dimensions (L x W x H) cm	90x90x50	120x100x50	130x100x65	130x100x80	150x120x80



The ResQshelter system is specially developed to provide first responders with the equipment they need and when they need it on short notice. The ResQshelter series is versatile and made to fit your purpose. Its inner width of 5.46 m makes it possible to fit two beds opposed to each other leaving almost 1.5 meters in between for personnel passing through. The ResQshelter are very easy to set up - no special knowledge is required. All sizes are standardized to make all shelters fit together.



Features

- Connecting ability
- Tightening belts
- Carrying bag
- Doors facilitate optimum modular configurations
- Fixing points for lighting elements
- Openings for electrical cables and heating
- Inflated in less than three minutes
- Lightweight: two-man handling
- Built-in safety valves
- Shelters can be connected to all other models
- Stays up for several days without reinflation
- Airframe design allows automatic deployment



Fields of use

- Shelter
- Field hospital
- Command post
- Mass Decontamination
- Base Camp
- Compound

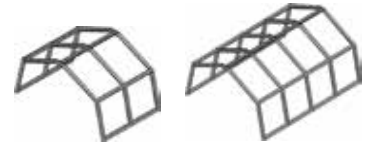

ResQshelter RS15

Optional features:

- textile waterbelts for installation on non-drillable floor
- connection sheet
- decontamination configuration: side liner + central separation curtain for shower installation
- water basin on the floor

Material:

Frame: standard Airtex270.1

Cover: Airtex455

Length: 330cm, Width: 544cm, Height: 290cm, Weight: 60kg
part no.: RS200-15



ResQshelter RS25

Optional features:

- textile waterbelts for installation on non-drillable floor
- connection sheet

Material:

Frame: standard Airtex270.1

Cover: Airtex455

Length: 460cm, Width: 544cm, Height: 270cm, Weight: 98kg
part no.: RS200-25



ResQshelter RS50 BMI

Optional features:

- textile waterbelts for installation on non-drillable floor
- connection sheet

Material:

Frame: standard Airtex270.1

Cover: Airtex455

Length: 760cm, Width: 605cm, Height: 330cm, Weight: 130kg
part no.: RS200-50-BMI



Window panel

1 window panel with 3 layers Mosquito net, transparent and full cover.

Length: 40cm, Width: 60cm

part no.: AIR421-C



Connection sheet

Panel on both side zippers to connect two tents.



Detachable groundsheet

Removable ground sheet with velcro, instead of fixed groundsheet.



Banner set

2 Banners, detachable with velcro.

Can be put either on the long side or the gable of the tent



Waterbelts

Set (2 pieces) of water belts for anchoring.

Capacity: 600 l. set of 2 pieces

Length: 400cm, Width: 30cm, Weigth: 8kg

part no.: AIR420A



Blower K

Blower with accessories for inflating and deflating shelter, cabin or basin. The blower can be delivered in a full set including 2 hoses, a blindcap, packed in a transport box.

Part no. AIR449 – Blower K
AIR449-S – Blower K set
Option: AIR447-A – Blower K hose



Pressure reducing valve

Pressure reducer for inflation of shelter, cabin or basin, to connect on BA Air cylinder. 200 - 300 Bar, incl. connection hose with male quick coupling.

Weight: 2,5kg
part no.: AIR440



Heater AIR30

For heating or ventilating air in shelters. Hoses for air inlet and outlet are available to recirculate air for optimal energy efficiency.

Length: 126cm, **Width:** 47cm, **Height:** 68,5cm
Airflow 1080m³/hr, fuel
Electric power: 2,3 Ah max 1x230V, 430W nom.
Output: 22,5 kW,
Fuel consumption: 2,45 l/h
Weight: 68 kg



Air conditioner

Split Aircos System for cooling the air inside the tents, the Evaporator unit is put inside the tent and connected with 3m long flexible piping with condenser unit outdoor.

Cooling capacity: 4,2 kW. **Air volume:** 640 m³/h. **Power input:** 1,4 kW
airconditioning
Length: 56cm, **Width:** 41cm, **Height:** 120cm, **Weight:** 76kg
part no.: AIR558
Option: AIR558-A – wooden transportation box



Presentation of decontamination range

Our decontamination range is meant to accompany you on every field of operation that needs a consistent, robust and mobile solution quickly deployable in case of pandemic disease or chemical contamination. The inflatable cabins offer a built-in shower system which can be fed with clear water or water mixed with decontamination chemicals; we can also offer retention basins and independent shower systems. Our systems allow decontamination of people in a minimum of time with a maximum efficiency and safety; to avoid human error, a minimum of assistance from third parties is needed during the decontamination process.



Features

- Adaptable, flexible solutions, from all-in-one cabins to separate accessories
- Possible integration with the rest of our product range
- Tents, accessories and spare parts can be purchased separately



Fields of use

- Fire brigades
- Field hospitals
- Military operations

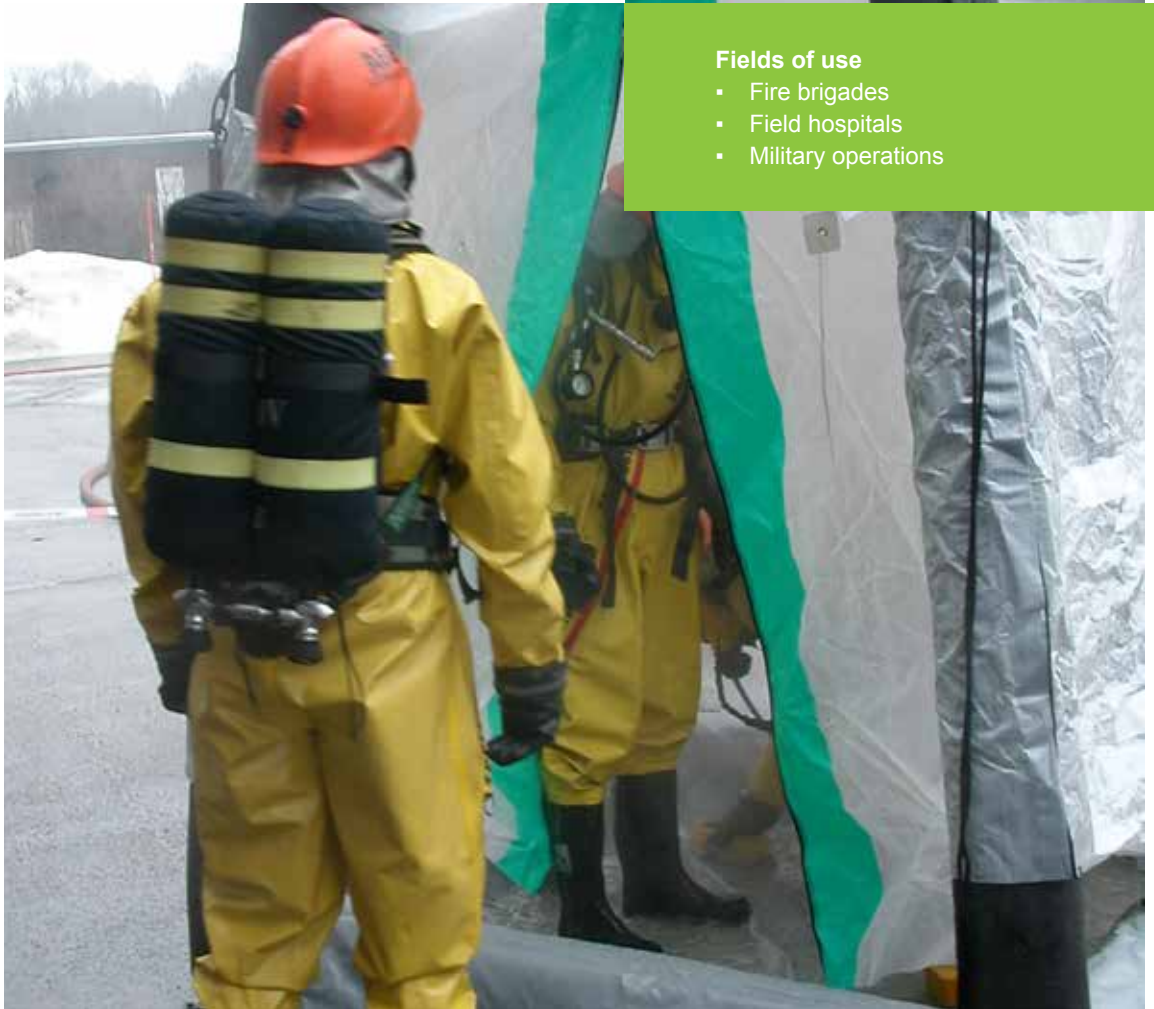

Did you know ?

Rubber is a material that does not allow penetration from chemical agents; contamination cannot migrate in it, unlike PVC. So PVC framed decon cabins should be reserved for non-chemical decontamination projects. Rubber frames are also more airtight and more resistant than PVC frames in general.

Common features to all cabins:

- Clearly marked entry (red) / exit (green)
- Inflation requires a Blower K or a pressure reducing valve (inflation with BA cylinder) to be ordered separately
- Standard couplings for connection to water system : Geka type
- Accessories in option :
- Transparent window panel with gloves for external help
- Decontamination accessories : brush, pistol



Deconcabin DC100

The smallest cabin of the range. Inflatable decontamination showercabin, rubber frame, shower space with colour coded entrance and exit, integrated basin, Inflated with Blower K or BA cylinder. Set up in 25 secs. Incl. repair kit, handpump, pegs, hammer, carry bag, manual.

Material:

Frame: Rubber

Curtain: Airtex800 (inclusive shower strip)

Length: 180cm, **Width:** 180cm, **Height:** 250cm, **Weight:** 45kg
part no.: AFW113D



Deconcabin DC150

The smallest cabin of the range which also includes a basin. Inflatable decontamination showercabin, rubber frame, shower space with colour coded entrance and exit, integrated basin and extended basin, Inflated with Blower K or BA cylinder. Set up in 30 secs. Incl. repair kit, handpump, pegs, hammer, carry bag, manual.

Material:

Frame: Rubber

Curtain: Airtex800 (inclusive shower strip)

Length: 380cm, **Width:** 200cm, **Height:** 250cm, **Weight:** 50kg
part no.: AFW112A



DeconCabin DC160

An inflatable shower cabin, consisting of an PVC frame, a shower space and a pre-decontamination basin.

Inflated with Blower K or BA cylinder. Set up in 35 secs. Incl. repair kit, handpump, pegs, hammer, carry bag, manual.

Material:

Frame: PVC,

Curtain: Airtex800 (inclusive special shower hose system)

Length: 380cm, **Width:** 200cm, **Height:** 260cm,

Weight: 60kg

part no.: AFW112AG



DeconCabin DC200

Inflatable decontamination showercabin, rubber frame, shower space with colour coded entrance and exit, integrated basin, Inflated with Blower K BA cylinder. Set up in 35 secs. Incl. repair kit, handpump, pegs, hammer, carry bag, manual.

Material:

Frame: Rubber,

Curtain: Airtex800 (inclusive shower strip)

Length: 250cm, **Width:** 250cm, **Height:** 270cm,

Weight: 55kg

part no.: AFW113A



DeconCabin DC300

Inflatable decontamination showercabin, rubber frame, shower space with colour coded entrance and exit, integrated basin and extended basin, Inflated with Blower K or BA cylinder. Set up in 40 secs. Incl. repair kit, handpump, pegs, hammer, carry bag, manual.

Material:

Frame: Rubber,

Curtain: Airtex800 (inclusive shower strip)

Length: 450cm, **Width:** 250cm, **Height:** 270cm

Weight: 65kg

part no.: AFW113B



DeconCabin DC400

Inflatable decontamination showercabin, rubber frame, extended showercabin with colour coded entrance and exit, integrated basin, Inflated with Blower K or BA cylinder. Set up in 50 secs. Incl. repair kit, handpump, pegs, hammer, carry bag, manual.

Material:

Frame: Rubber,

Curtain: Airtex800 (inclusive shower strip)

Length: 450cm, **Width:** 250cm, **Height:** 270cm, **Weight:** 69kg

part no.: AFW113C



DeconCabin DC450

Inflatable decontamination showercabin, rubber frame, double showercabin with 2 colour coded entrances and exits, integrated basin and extended basin, Inflated with Blower K or BA cylinder. Set up in 30 secs. Incl. repair kit, handpump, pegs, hammer, carry bag, manual.

Material:

Frame: Rubber,

Curtain: Airtex800 (inclusive shower strip)

Length: 450cm, **Width:** 480cm, **Height:** 270cm, **Weight:** 75kg

part no.: AFW113E

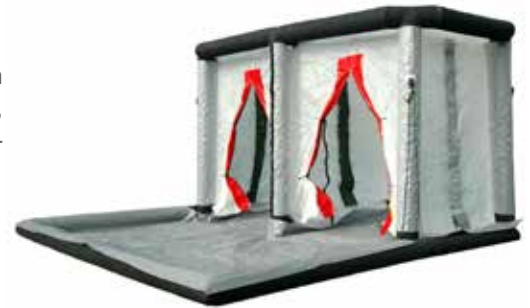

DeconCabin DC420

Inflatable decontamination showercabin, rubber frame, double showercabin with 2 colour coded entrances and exits, integrated basin, Inflated with Blower K or BA cylinder. Set up in 50 secs. Incl. repair kit, handpump, pegs, hammer, carry bag, manual.

Material:

Frame: Rubber,

Curtain: Airtex800 (inclusive shower strip)

Length: 450cm, **Width:** 250cm, **Height:** 270cm, **Weight:** 69kg

part no.: AFW113CD



These basins can be used for boots decontamination or as collection basins for showers with external assistance. The basin tubes are made of rubber material. All liners can be replaced if damaged or contaminated.



DeconBasin DB150

Decontamination basin for collecting contaminated water, inflated by Blower K or BA cylinder. Inflated in 15 sec.. Incl. interchangeable liner and overpressure valve.

Material:

Frame: Rubber, Liner: Airtex300 (Resistance table D)

Length: 150cm, Width: 150cm, Height: 25cm

Weight: 10kg

part no.: afw111f



DeconBasin DB250

Decontamination basin for collecting contaminated water, inflated by Blower K or BA cylinder. Inflated in 18 sec.. Incl. interchangeable liner and overpressure valve.

Material:

Frame: Rubber, Liner: Airtex300 (Resistance tabel D)

Length: 250cm, Width: 250cm, Height: 25cm

Weight: 15kg

part no.: AFW111D



DeconBasin DB500

Decontamination basin for collecting contaminated water, inflated by Blower K or BA cylinder. Inflated in 20 sec.. Incl. interchangeable liner and overpressure valve.

Material:

Frame: Rubber, Liner: Airtex300 (Resistance tabel D)

Length: 300cm, Width: 500cm, Height: 23cm

Weight: 20kg

part no.: afw111c



We aim at supplying you not only with tents, but with a full turnkey decontamination system. Our accessories can be used separately or together ; the smaller ones are installed in stackable boxes for easier handling and storage.



Fields of use

- Decontamination
- Field hospital
- Fire brigades
- Military operations
- Disaster relief

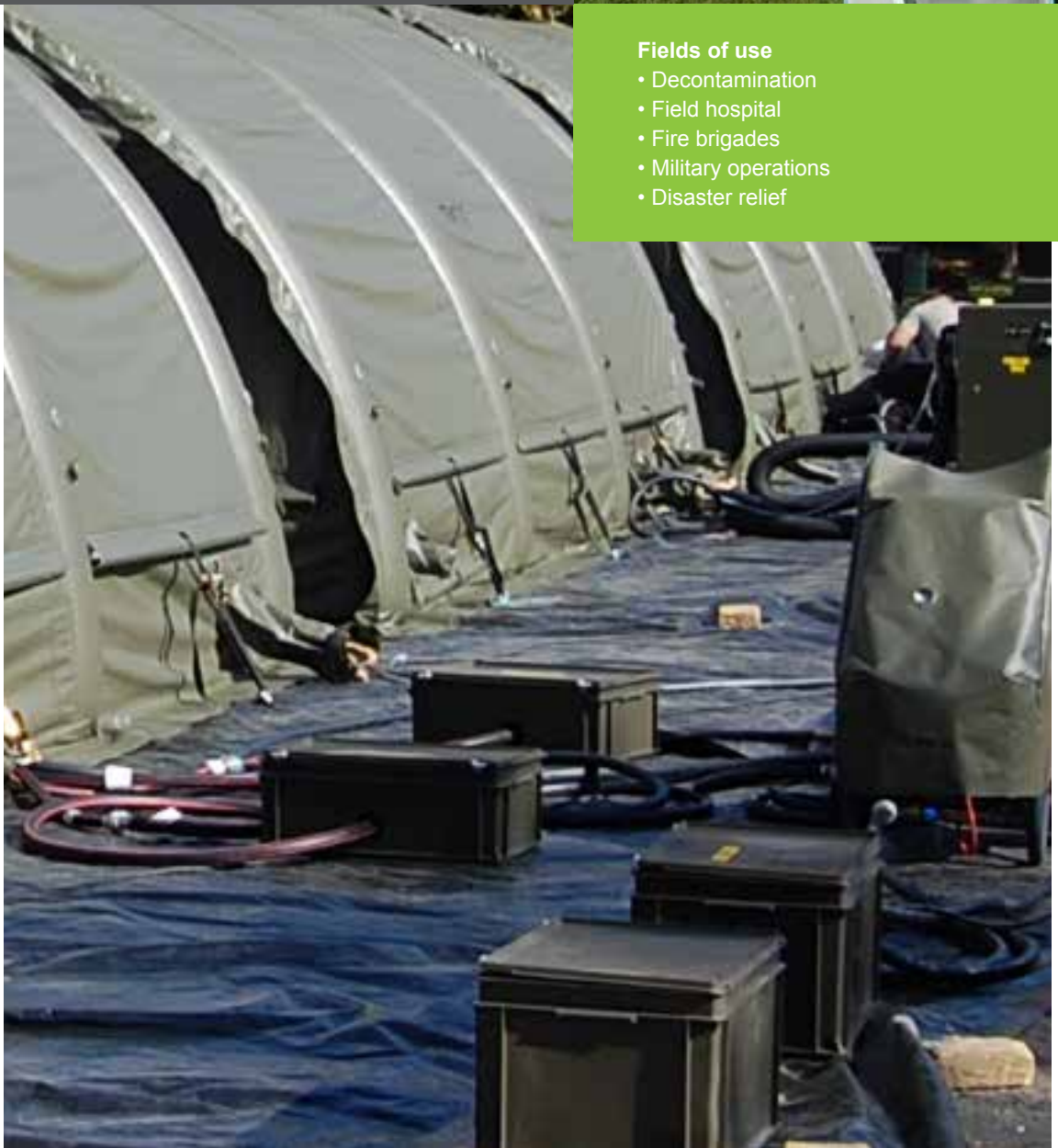

Waterheater

Portable self heating water system, Instantaneous warm water for decontamination. Capacity: 50 l/min., Delta T 30 degrees C (at 3000 l/hr.). Adjustable and automatic temperature control: up to 70C°, 61000 kcal/hr., Max. pressure 6 Bar. Diesel consumption 7,8 l/hr. Electric Motor 71 kW, 220V/50Hz. incl Nato Jerry can.

Material: heating element steel

Length: 63cm, Width: 66cm, Height: 97cm, Weight: 83kg

part no.: ACD250

2 options available:

- Part no. ACD250 : Water heating element: steel
- Part no. ACD255 : Water heating element: stainless steel

We recommend the use of stainless steel heating resistance on field operations for its minimal maintenance.



Hazmat Shower

Decontamination shower for larger groups, erected in 15 sec. Safe and efficient to wash persons wearing chemical suits. 9 special spraying nozzles. Capacity: 50 l/min. at 7 Bar.

Material: fully stainless steel

Length: 114cm, Width: 64cm, Height: 210cm, Weight: 22kg

part no.: ACD112A



Deconcircle

Decontamination shower octagonal circle with handle assembled in 15 sec. Safe and efficient to wash persons wearing chemical suits. 8 special spraying nozzles. Capacity: 45 l/min. at 7 Bar.

Material: stainless steel

Weight: 3,8kg

part no.: ACD112KII

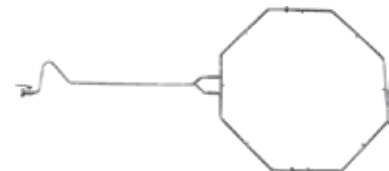

Hydrophor Pump

Electric water supply pump for decon systems, Runnig fully automatic. incl. manometer and separate expansion tank, Capacity 60 L/min., 4 Bar, Motor IP65 230 Volt, 800W. For easy handling mounted in 2 box's. Standard Geka couplings (0,75Kw)

Length: 60cm, Width: 40cm, Height: 34cm, Weight: 35kg

part no.: AFZ710

Option: the hydrophor pump can be supplied in 110V

part no.: AFZ710-110V



Watermanifold WM750

1 inlet, 4 outlets

Manifold for Decon and drinking water systems with 4 x 1" outlet valves, temperature and pressure gauges. Material: pipes copper, valves brass. For easy handling mounted in Box. Standard Geka couplings.

Length: 35cm, Width: 45cm, Height: 50cm, Weight: 10kg
part no.: ZPS750



Watermanifold WM751

1 inlet, 2 outlets

Water manifold, 1 inlet 2 outlets 1" with valves. For Easy handling mounted on board andpacked in Box, Standard Geka couplings.

Length: 40cm, Width: 30cm, Height: 12cm, Weight: 3kg
part no.: ZPS751



Inducer

Inducer to mix detergent solvents or decontamination fluids. Maintains set percentage regardless of flow and pressure. Flow capacity 50 L/min. Pressure Min. 0,30 Bar, Max. 6 Bar. Adjustable percentage 0,2% - 2%. For easy handling mounted in Box. Standard Geka couplings

Length: 60cm, Width: 40cm, Height: 22cm, Weight: 4,5kg
part no.: ACD201a

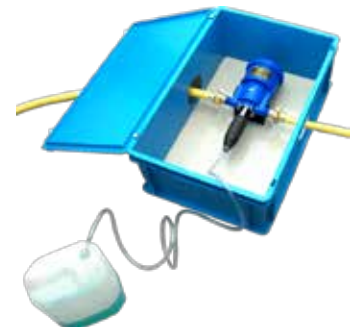

Wastepump

Evacuation Pump for contaminated decon water of MD Airshelter or Decon cabin/basin. Motor: IP 68, 0,25 kW, 24 Volt 50 Hz - 60 Hz, thermal safety 10m cable. Automatic levelswitch. minimum level 4 mm.. Capacity: 3,5 m3/hour. Pressure hose connection Geka. Suction holes Ø 17mm.

Length: 40cm, Width: 30cm, Height: 34cm
part no.: AFZ720

Option: the waste pump can be supplied in

- 110V : part no. : AFZ720-B
- 24V : part no. : AFZ720-A



Set of hoses for Mass Decontamination Airshelter

Set of hoses for a Mass Decon System, Standard coupling Geka For easy handling packed in Box

part no.: ZPS201A



Water pressure reducing valve

Water pressure release valve 1", adjustable: 1 to 12 Bar

Material: brass. Standard couplings Geka

Weight: 1,1kg

part no.: ON3802



Fluidbag

Closed container to collect hazardous fluids or feed your shower system, 500 litres. Incl. double PE liner, 2 in/outlets 2" female

Weight: 7kg

part no.: AFW120A

The fluidbag can be fitted with a valve including coupling for connection to your water system:

Valve fitted with Geka coupling: part no. AFW121G

Material: PE

Coupling 2" male and 1 1/4 " male



Deconbrush

Decon brush with spiral hose for decontamination of non ambulatory persons, flow 5 l/min. Standard quick coupling male

part no.: ZPS112



Deconpistol

Decon pistol with spiral hose for decontamination of non ambulatory persons, adjustable flow max 15 l/min. Standard quick coupling male.

part no.: ZPS114F



Elevation grid

Floor slats, elevated floor in basin of cabin or Mass Decon Airshetler.

Length: 120cm, Width: 60cm, Height: 2,5cm, Weight: 2kg
part no.: AIR416



Conveyor

Conveyor for moving non ambulatory victims on transfer board through decontamination unit. Can accept many stretchers and spineboard systems. 2m segments interconnectable, 7 rolling bars.

Material: Aluminium

Length: 201cm, Width: 50cm, Height: 75cm, Weight: 17kg
part no.: ZPS503



Transfer board

Transfer board for Conveyor, load capacity is : 300 lb. (136kg) per lineal foot.

Length: 184cm, Width: 43cm, Height: 5cm, Weight: 5,4kg
part no.: zps501



Rescue Cushion 16 M

This cushion is used to rescue people jumping or falling from a building in case of a fire. The maximum jumping height is 16 meters / 51 ft (test along the procedure required by DIN 14151-3). The frame can be inflated either with a compressed air cylinder (DIN-type coupling) or an electrical inflator.

Colour of landing area: white - Walls: Orange

Length: 347cm, Width: 347cm, Height: 170cm, Weight: 55kg

part no.: CUS160



Rescue Cushion 23 M

This cushion is used to rescue people jumping or falling from a building in case of a fire. The maximum jumping height is 23 meters / 73 ft (test along the procedure required by DIN 14151-3). The frame can be inflated either with a compressed air cylinder (DIN-type coupling) or an electrical inflator.

Colour of landing area: white - Walls: Orange

Length: 450cm, Width: 450cm, Height: 240cm, Weight: 80kg

part no.: CUS200





LOSBERGER DE BOER

Losberger SAS

Rapid Deployment System

58A rue du Dessous des Berges

75013 Paris - France

Tel. +33 (0)1 46 72 42 69

Fax. +33 (0)1 45 85 48 46

Email: cobtact@losbergerdeboer.com

Internet: www.losberger-rds.com